



DIRECT FIRED

LPG Vaporizer



DIRECT FIRED

the power of innovation



Algas-SDI Direct Fired vaporizers are designed to convert liquid LPG to LPG vapor for a variety of applications.

No electricity required! Simple to install!

Table	
Exposure	Minimum Distance From Vaporizer Required
Storage tank	10 feet/3M
Storage tank shutoff	15 feet/4.5M
Point of transfer	15 feet/4.5M
Nearest important building or group of buildings or line of adjoining property which may be built upon (except buildings in which vaporizer is installed)	25 feet/7.6M

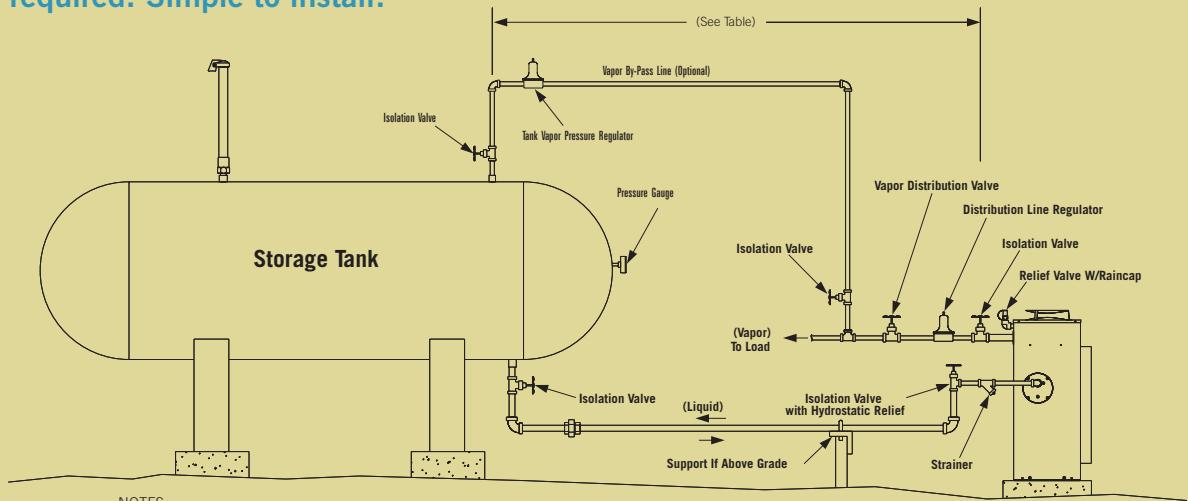

NOTES:

- 1) Hydrostatic head not to be exceeded by liquid piping losses.
- 2) Install Vaporizer Distribution Line Regulator upstream of Tank Vapor pressure connection point.
- 3) Set Distribution Line Regulator 2-4 PSIG/.14kg/cm²-.281kg/cm² higher than Tank Vapor Pressure Regulator set point.
- 4) No check valves in Liquid Line; liquid must be able to flow both directions.

Vaporizer Operation

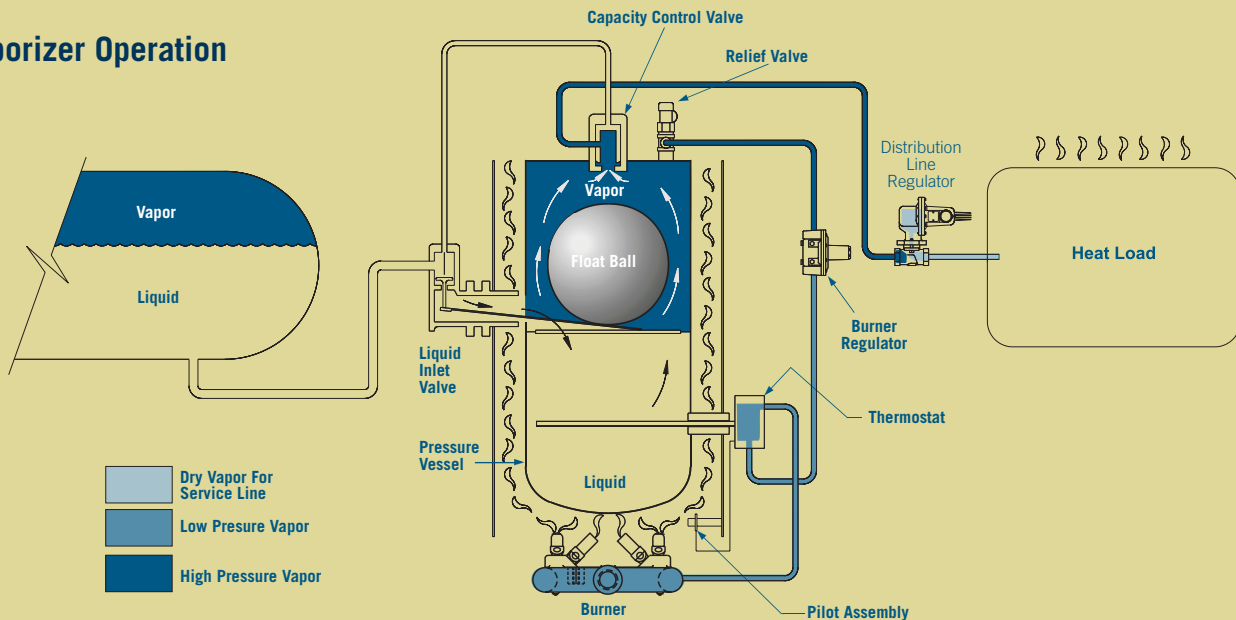

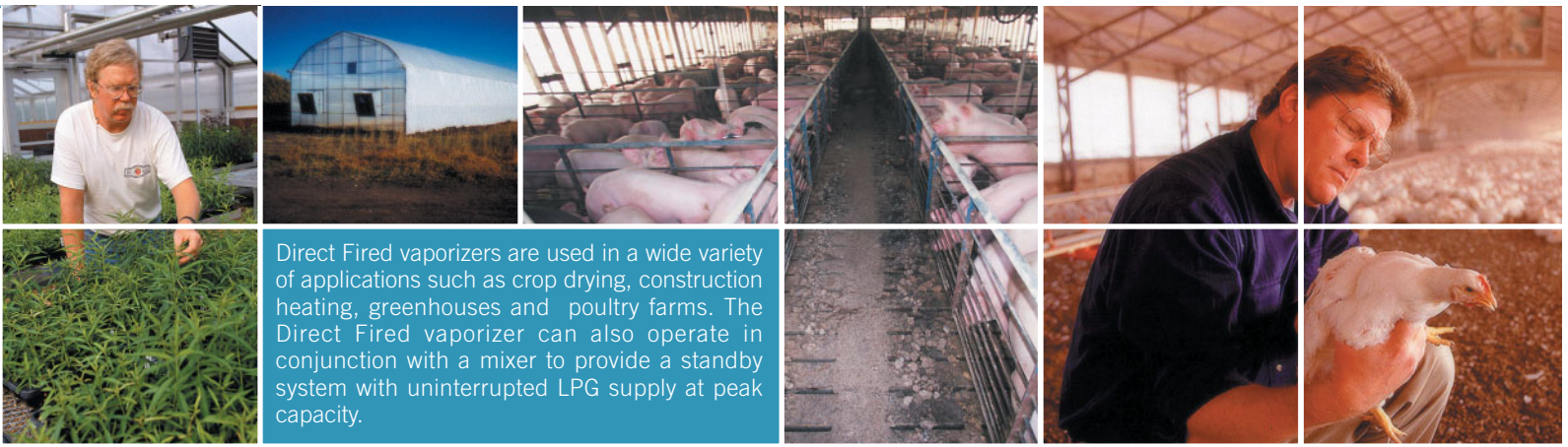

Direct Fired vaporizers are used in a wide variety of applications such as crop drying, construction heating, greenhouses and poultry farms. The Direct Fired vaporizer can also operate in conjunction with a mixer to provide a standby system with uninterrupted LPG supply at peak capacity.

DIMENSIONS

	A	B	C
40/40H	35" (89 cm)	29" (74 cm)	19-3/4" (50 cm)
60/60H	44" (112 cm)	38" (96.5 cm)	28-1/2" (72 cm)
80/40H	35" (89 cm)	29" (74 cm)	19-3/4" (50 cm)
120/60H	44" (112 cm)	38" (96.5 cm)	28-1/2" (72 cm)

40/40H and 60/60H VAPORIZERS

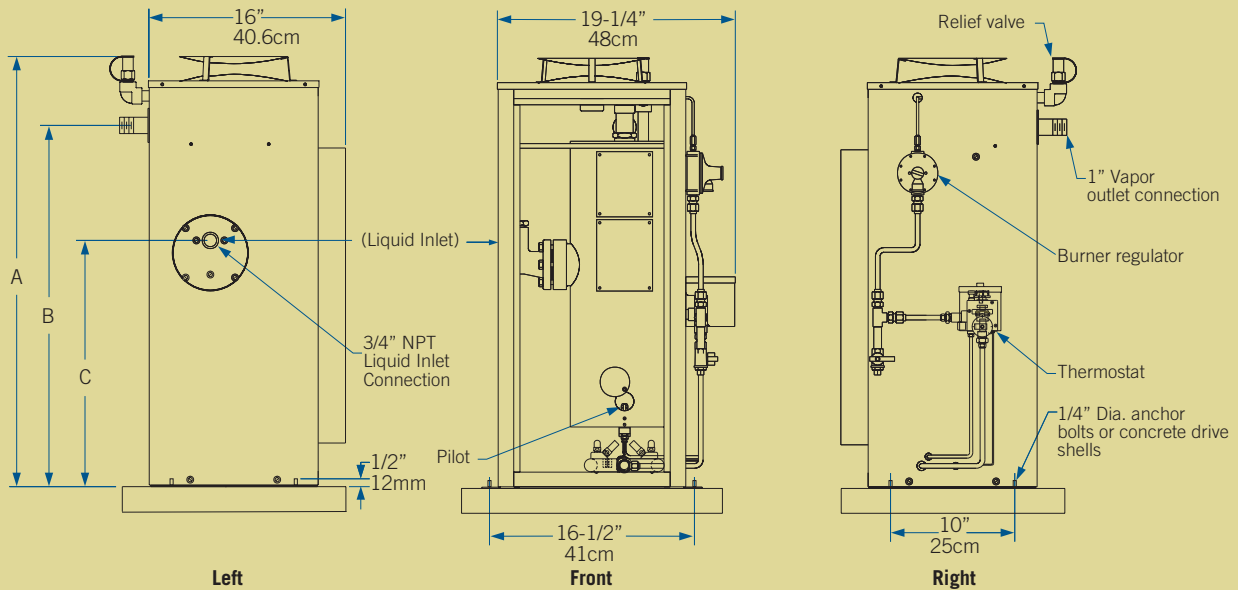

80/40H and 120/60H VAPORIZERS

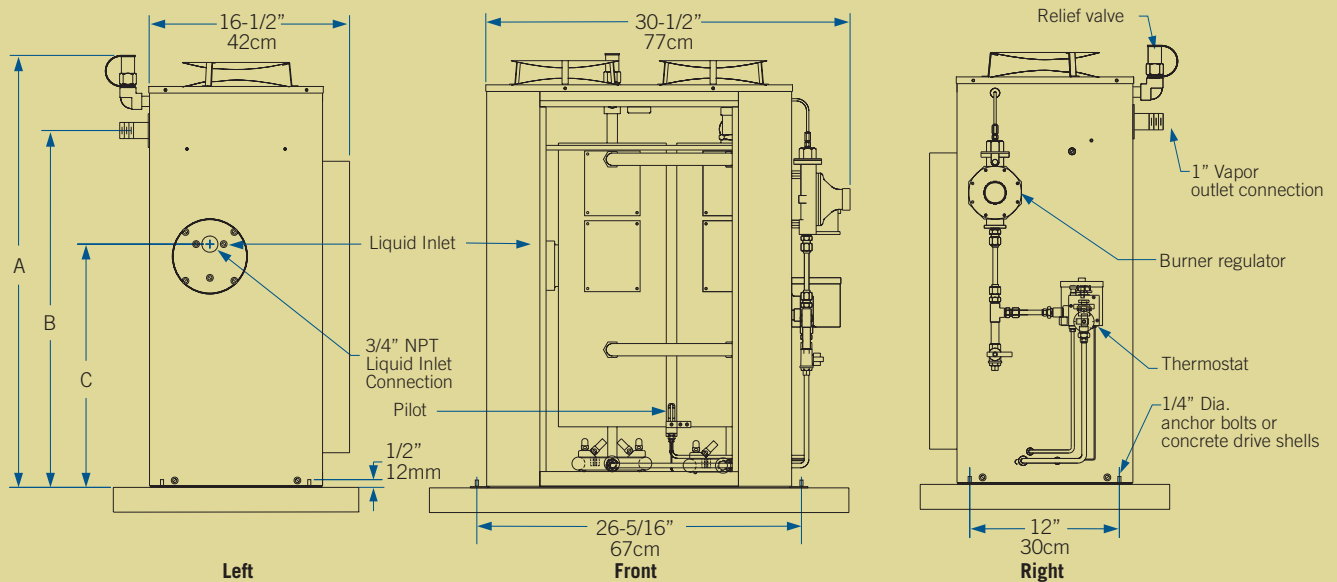



DIRECT FIRED SPECIFICATIONS

Model		40/40H	60/60H	80/40H	120/60H
Vaporizer Type		Feed Through	Feed Through	Feed Through	Feed Through
Vaporization Capacity					
lbs/hr		176	264	352	528
kg/hr		80	120	160	240
million Btu/hr		3.64	5.46	7.28	10.92
million kcal/hr		0.91	1.37	1.83	2.75
U.S. Gal/hr (nominal)		40	60	80	120
Heat Exchanger					
Surface Area,	ft ²	0.51	0.77	1.02	1.53
	m ²	0.047	0.71	0.94	1.41
Design Pressure,	psig	250	250	250	250
	kg/cm ²	17.6	17.6	17.6	17.6
Burner Heat Input					
BTU/hr		51,360	77,040	102,720	154,080
kcal/hr		12,945	19,414	25,885	38,828
Relief Valve Set Point					
psig		250	250	250	250
kg/cm ²		17.6	17.6	17.6	17.6
Shipping Weight					
lbs.		155	175	220	275
kg.		70.3	79.5	99.8	125
Shipping Dimensions					
in. (Depth x Height x Width)		21" x 41" x 22"	21" x 50" x 22"	21" x 41" x 35"	21" x 50" x 35"
cm. (Depth x Height x Width)		53 x 104 x 56	53 x 127 x 56	53 x 104 x 89	53 x 127 x 89
Approvals		CE, PED(DNV), UL (U.S. and Canada), FM			
Optional Accessories		Automatic Ignition Kit – available in 110V or 220V AC, or 9V DC (Battery), Economy Operation Kit, Filtaire Heavy Ends Filter, Relief Valve Pipe Away Adapter			



1140 NW 46th Street
 Seattle, Washington,
 USA 98107
 Phone: 206-789-5410
 FAX: 206-789-5414
 www.algas-sdi.com

Contact Your Distributor Today:



ECLIPSE
 Algas • SDI
 Form DF-0304